

Himpoo[®]

Hi-Station



Hi-Station 1100*2



Hi-Station 750(mini)

Hi Station, best for your daily life



Hi-Station 750(mini)

Dimensions:	255*542*455mm
Voltage:	220~240V/50Hz
Power:	P1:1.1KW P2:0.75KW
Flow rate:	Qmax 15m ³ /h
Head:	Hmax 10m
Start Level:	20cm
Weight:	NW:22KG
Tank Volume:	20L



Hi-Station 1100

Dimensions:	500*500*455mm
Voltage:	220~240V/50Hz
Power:	P1:1.1KW P2:0.75KW
Flow rate:	Qmax 33m ³ /h
Head:	Hmax 13m
Start Level:	25cm
Weight:	NW:30KG
Tank Volume:	40L



Hi-Station 1100*2

Dimensions:	680*660*455mm
Voltage:	220~240V/50Hz
Power:	P1:1.1KW*2 P2:0.75KW*2
Flow rate:	Qmax 43m ³ /h
Head:	Hmax 13m
Start Level:	25cm
Weight:	NW:80KG
Tank Volume:	60L

Hi-Station 750(mini)



▲ PRODUCT PARAMETERS

Hi-Station lifting pump is a large-scale sewage product with modern design

Water inlet:	DN110mm*3,DN50mm*5	Dimensions:	255*524*455mm
Outlet:	DN50mm	Cable length:	5m
Air Vent:	DN50mm	HP value:	5-8
Liquid Temperature:.	45°C	Voltage:	220~240V/50Hz
Max Liquid temperature:	65°C/10min	Power:	P1:1.1KW P2:0.75KW
Environmental temperature:	45°C	Flow rate:	Qmax 15m ³ /h
Insulation class:	F-class	Head:	Hmax 10m
Maximum Particulate Matter:	35mm	Rotating speed:	2800 r/min
Protection level:	IP68	Current:	5.5A
Volume of water tank:	20L	Take-off water level:	20cm
Material of header tank:	HDPE	Weight:	NW:22KG
Switch system:	Air switch	Prevent sedimentation:	yes

Parts drawing



Rubber pipe fittings
Sealing for tank to pipe



Large soft connector
Link machine and PVC



O-ring
φ110~130mm



O-ring
φ43~67mm



Locking chuck
φ57~62mm



Small soft connector
Link machine and PVC

Hi-Station 750(mini)

min water level

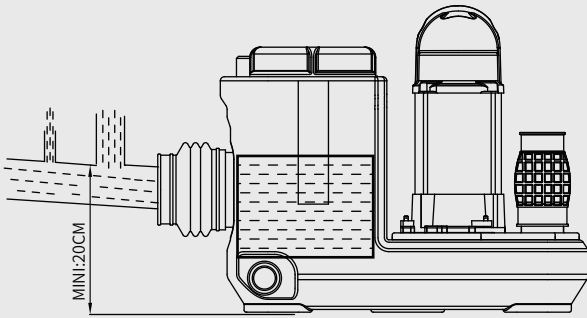

Head chart

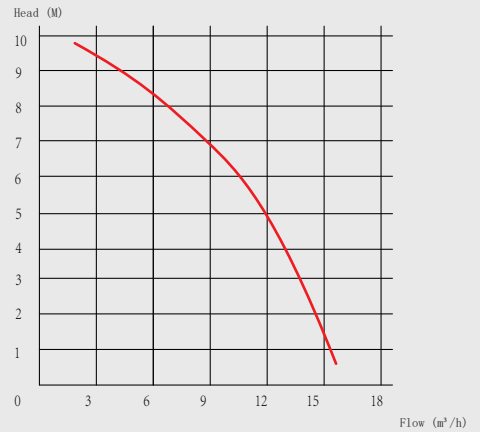

Dimension

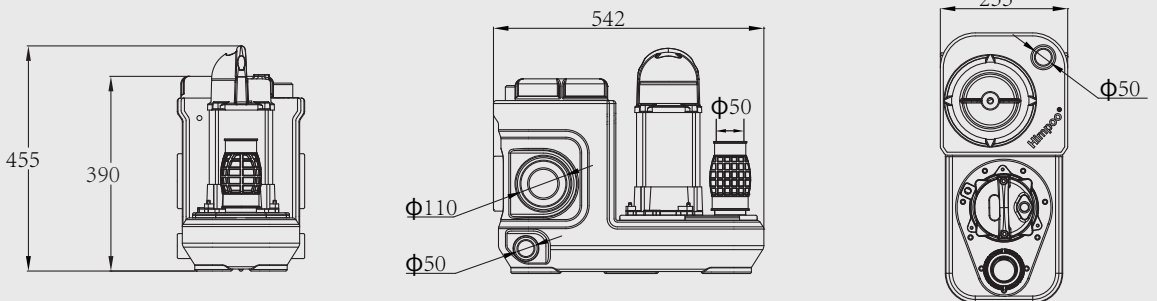

Hi-Station 1100

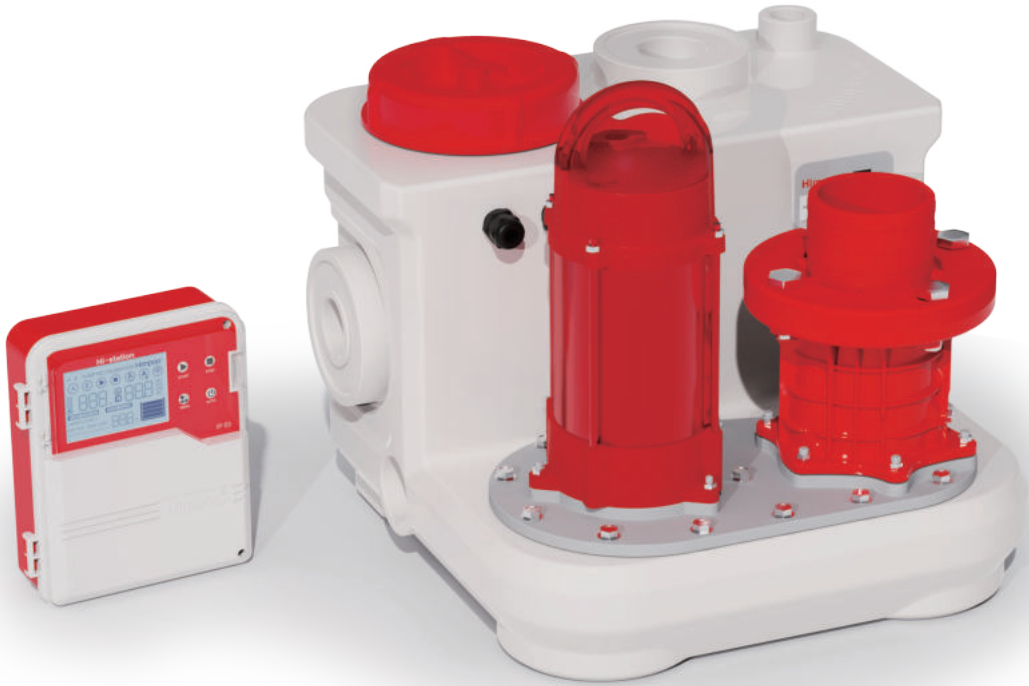

▲ PRODUCT PARAMETERS

Hi-Station lifting pump is a large-scale sewage product with modern design

Water inlet:	DN110mm*4, DN50mm*6	Dimensions:	500*500*455mm
Outlet:	DN90mm	Cable length:	5m
Air Vent:	DN50mm	HP value:	5-8
Liquid Temperature: :	45°C	Voltage:	220~240V/50Hz
Max Liquid temperature:	65°C/10min	Power:	P1:1.1KW P2:0.75KW
Environmental temperature:	45°C	Flow rate:	Qmax 33m ³ /h
Insulation class:	F-class	Head:	Hmax 13m
Maximum Particulate Matter:	40mm	Rotating speed:	2800 r/min
Protection level:	IP68	Current:	5.5A
Volume of water tank:	40L	Take-off water level:	25cm
Material of header tank:	HDPE	Weight:	NW:30KG
Switch system:	Float switch	Prevent sedimentation:	yes

Parts drawing



Rubber pipe fittings
Sealing for tank to pipe



Large soft connector
Link machine and PVC



O-ring
φ110~130mm



Anti-cloth pipe
Inside the anti-cloth bag φ90mm



Locking chuck
φ98~103mm



Small soft connector
Link machine and PVC



O-ring
φ43~67mm

Hi-Station 1100

min water level

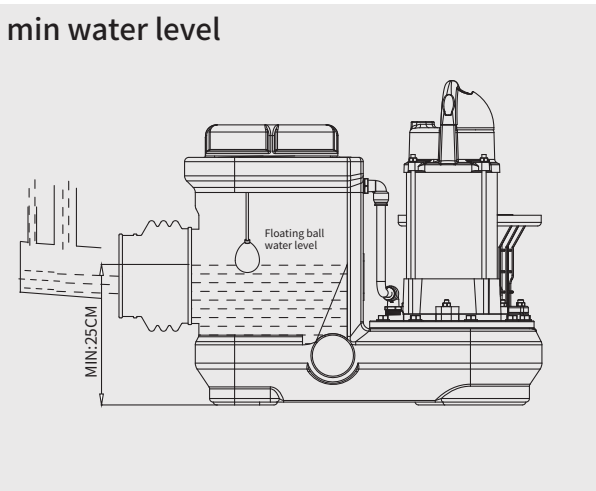

Head chart



Dimension

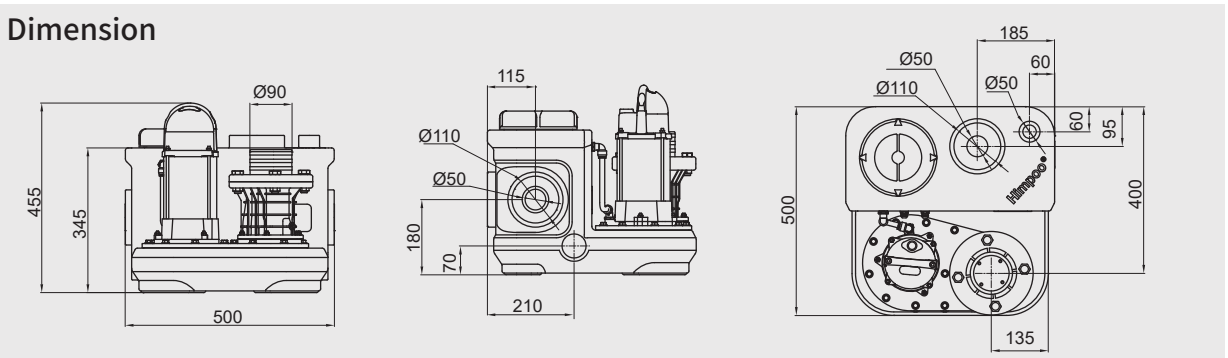

Hi-Station 1100*2



▲ PRODUCT PARAMETERS

Hi-Station lifting pump is a large-scale sewage product with modern design

Water inlet:	DN110mm*4,DN50mm*6	Dimensions:	680*660*455mm
Outlet:	DN90mm	Cable length:	5m
Air Vent:	DN50mm	HP value:	5-8
Liquid Temperature:.	45°C	Voltage:	220~240V/50Hz
Max Liquid temperature:	65°C/10min	Power:	P1:1.1KW*2 P2:0.75KW*2
Environmental temperature:	45°C	Flow rate:	Qmax 43m ³ /h
Insulation class:	F-class	Head:	Hmax 13m
Maximum Particulate Matter:	40mm	Rotating speed:	2800 r/min
Protection level:	IP68	Current:	5.5A
Volume of water tank:	60L	Take-off water level:	25cm
Material of header tank:	HDPE	Weight:	NW:80KG
Switch system:	Float switch	Prevent sedimentation:	yes

Parts drawing



Rubber pipe fittings
Sealing for tank to pipe



Large soft connector
Link machine and PVC



O-ring
φ110~130mm



Anti-cloth pipe
Inside the anti-cloth bag φ90mm



Locking chuck
φ98~103mm



Small soft connector
Link machine and PVC



O-ring
φ43~67mm

Hi-Station 1100*2

min water level

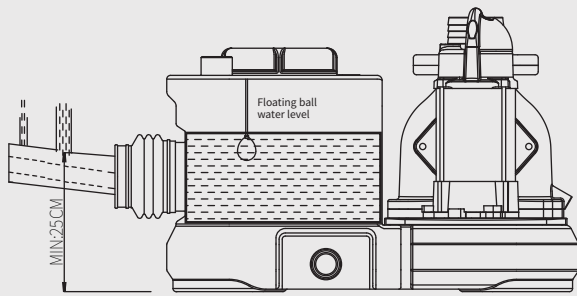

Head chart

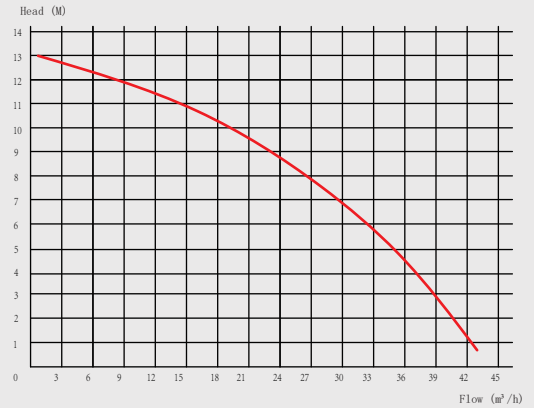

Dimension

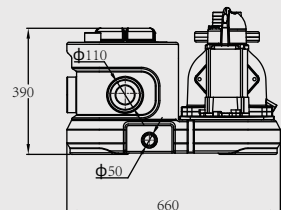
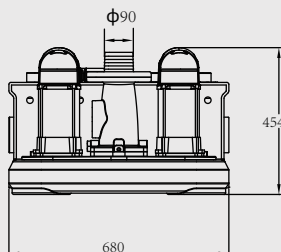
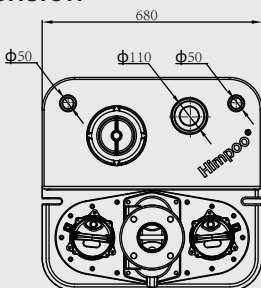

FAQ:

Q1 Motor kw rpm 230v 1Ph or 400v 3ph or both available?

Hi Station lift pump, Only 100V~240V

Q2 Except RED Color? Can it be different color possible?

Hi Station lift pump, Only can make red color

Q3 Can OEM and package as customer request brand?

Hi Station lift pump, Himpoo brand package only (Homac had register successful in Germany)

Q4 How & when pump starts & stops?

1. Adjustable start/stop level (Factory settings:25cm)
Water start and stop level: 20~25cm
2. Adjustable delay time (Factory settings: 2 seconds)
Start: When water raise to 25cm, the pump will start 2 sec later.
Stop: The pump will stop 2 sec later, if the water less than 25cm

Q5 Is there normally open volts free contact available?

Hi Station lift pump, Have normally open volts free contact, which will close when pump trips or has high level alarm activation

Q6 which kind of alarm and how does work?

Hi Station lift pump, The control-box have voice alarm when has high level or blocked

Q7 Does it have any Anti-settling protection function?

Hi Station lift pump, Have Anti-settling protection

Q8 What the max liquid temperature can been using

Hi Station lift pump, Max Liquid temperature:45° C (65° C in 10 minutes)

Q9 What' s the Max Particulate Matter, does it have cutter?

Hi Station lift pump is vortex pump, without cutter, Max free passage is 40mm

Q10 What' s the warranty?

Hi Station lift pump, Warranty 2 years

Q11 What' s the MOQ and delivery time?

Hi Station lift pump, MOQ; 5pcs. Delivery time: 15days

Q12 Does it have 2 pumps or others items?

Hi-Station 750(mini)
Hi-Station 1100 (1 pump)
Hi-Station 1100x2 (2 pumps)

PACKAGE

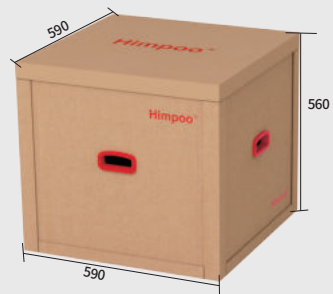

Himpoo®

HOMAC PRODUCTS LIMITED

(Ningbo Homic Electrical Appliance Co.Ltd)

Add: No.369, South of Dongshao, Zhuangqiao Street, Jiangbei District, Ningbo city, Zhejiang Province, China

Email: Leo@chinamacerator.com www.chinamacerator.com

M.T: 0086-13884443535 Wechat: 0086-13884443535 WhatsApp:0086-13884443535