

# TOP-FLOOR

## Submersible DRAINAGE pumps

 Clear water

 Domestic use



### PERFORMANCE RANGE

- Flow rate up to **170 l/min** (10.2 m<sup>3</sup>/h)
- Head up to **10.4 m**

### APPLICATION LIMITS

- **3 m** maximum immersion depth (with a sufficiently long power cable)
- Maximum liquid temperature **+40 °C** (Maximum liquid temperature +90 °C for a maximum of 3 minutes intermittent service)
- Passage of suspended solids up to **Ø 2 mm**
- Suction down to **2 mm** above ground level
- Continuous service **S1**

### CONSTRUCTION AND SAFETY STANDARDS

The pumps are complete with a **5 m** power cable

EN 60335-1  
IEC 60335-1  
CEI 61-150

EN 60034-1  
IEC 60034-1  
CEI 2-3



### CERTIFICATIONS

Company with management system certified DNV  
ISO 9001: QUALITY

### INSTALLATION AND USE

The **TOP-FLOOR** series is suitable for use with **clear water** that does not contain abrasive particles.

Because of their ability to drain water to a level of 2 millimetres above ground level, they are suitable for use in domestic emergencies where a small area must be drained to the lowest possible level.

### PATENTS - TRADE MARKS - MODELS

- Registered EU Design n. 342159-0011

### OPTIONS AVAILABLE ON REQUEST

- Pumps with float switch
- Special mechanical seal
- Pumps with a **10 m** long power cable.
  - ➔ N.B.: Standard EN 60335-2-41 states that the power cable must be 10 m long for outdoor applications
- Other voltages

### GUARANTEE

2 years subject to terms and conditions

### CHARACTERISTIC CURVES AND PERFORMANCE DATA

60 Hz n= 3450 min<sup>-1</sup>

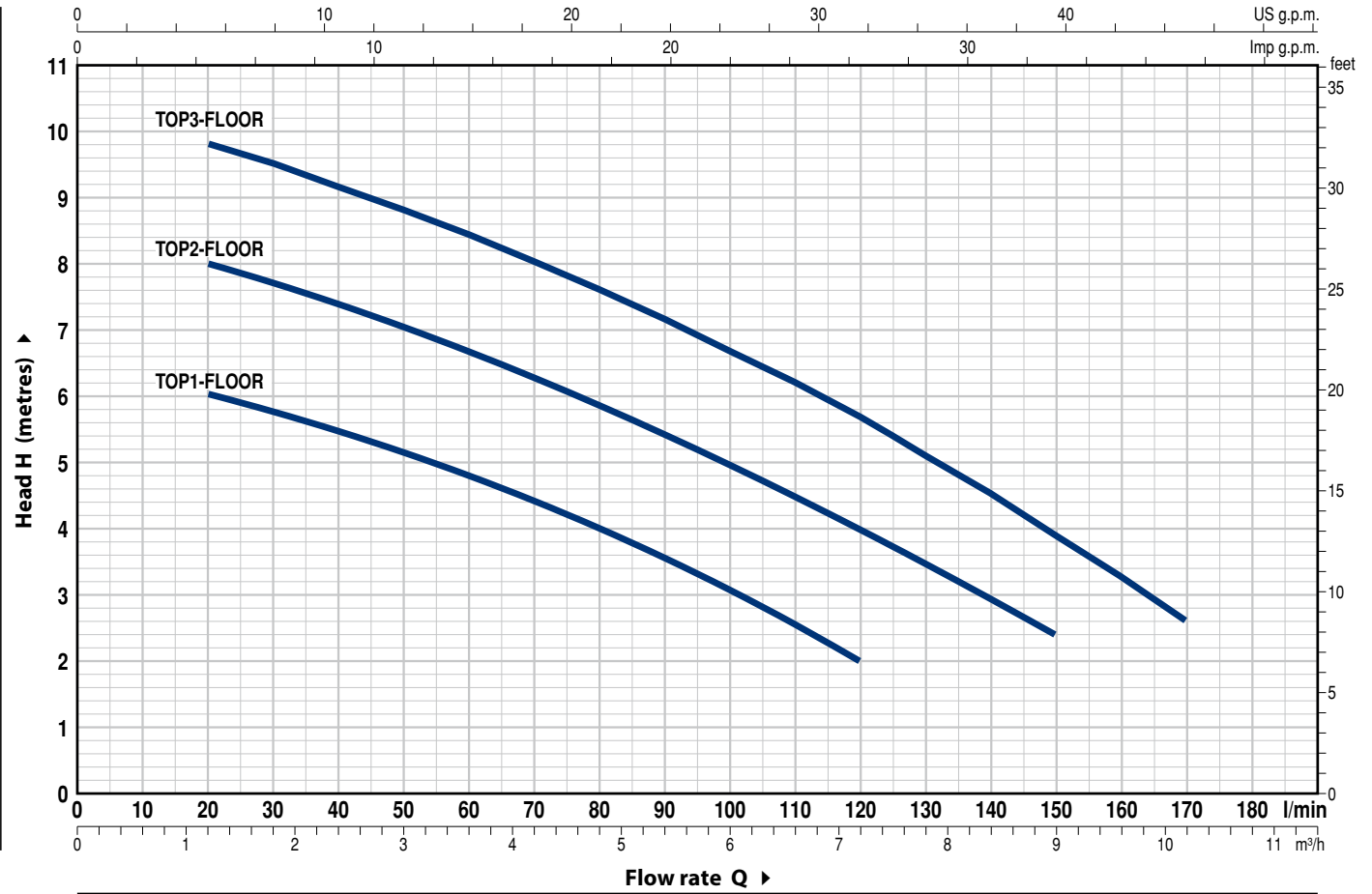

MODEL Single-phase	POWER (P <sub>2</sub> )		Q	Flow rate											
	kW	HP		0	1.2	2.4	3.6	4.8	6.0	7.2	7.8	9.0	10.2		
			l/min	0	20	40	60	80	100	120	130	150	170		
TOP 1-FLOOR	0.25	0.33	H metres	6.5	6	5.5	4.8	4	3.1	2					
TOP 2-FLOOR	0.37	0.50		8.5	8	7.4	6.7	5.9	5	4	3.5	2.4			
TOP 3-FLOOR	0.55	0.75		10.4	9.8	9.2	8.4	7.6	6.7	5.7	5.1	3.9	2.6		

Q = Flow rate H = Total manometric head

Tolerance of characteristic curves in compliance with EN ISO 9906 Grade 3B.

# TOP-FLOOR

## POS. COMPONENT CONSTRUCTION CHARACTERISTICS

1	<b>PUMP BODY</b>	Technopolymer
2	<b>SUCTION FILTER</b>	Technopolymer
3	<b>SUCTION PLATE</b>	Stainless steel AISI 304
4	<b>DIFFUSER</b>	Technopolymer
5	<b>IMPELLER</b>	Noryl
6	<b>MOTOR CASING</b>	Stainless steel AISI 304
7	<b>MOTOR CASING PLATE</b>	Stainless steel AISI 304
8	<b>MOTOR SHAFT</b>	Stainless steel AISI 431

### 9 SHAFT WITH DOUBLE SEAL AND OIL CHAMBER

<i>Seal Model</i>	<i>Shaft Diameter</i>	<i>Materials</i>		
		<i>Stationary ring</i>	<i>Rotational ring</i>	<i>Elastomer</i>
STA-12R	Ø 12 mm	Ceramic	Graphite	NBR

10	<b>LIP SEAL</b>	Ø 12 x Ø 19 x H 5 mm
----	-----------------	----------------------

11	<b>BEARINGS</b>	6201 ZZ / 6201 ZZ
----	-----------------	-------------------

### 12 CAPACITOR

<i>Pump Single-phase</i>	<i>Capacitance (220 V)</i>		<i>(110 V or 127 V)</i>
TOP 1-FLOOR	10 µF 450 VL	16 µF - 250 VL	
TOP 2-FLOOR	10 µF 450 VL	16 µF - 250 VL	
TOP 3-FLOOR	14 µF 450 VL	16 µF - 250 VL	

### 13 ELECTRIC MOTOR

**TOP-FLOOR:** single-phase 220 V - 60 Hz with thermal overload protector incorporated into the winding.

- Insulation: class F
- Protection: IP X8

### 14 HANDLE ASSEMBLY (resin sealed)

Complete with 5 metres long "H07 RN-F" **power cable** with Schuko plug

### 15 HOSE CONNECTOR WITH RING NUT

- Ø 25 mm hose connection for TOP1-FLOOR
- Ø 35 mm hose connection for TOP2-FLOOR, TOP3-FLOOR

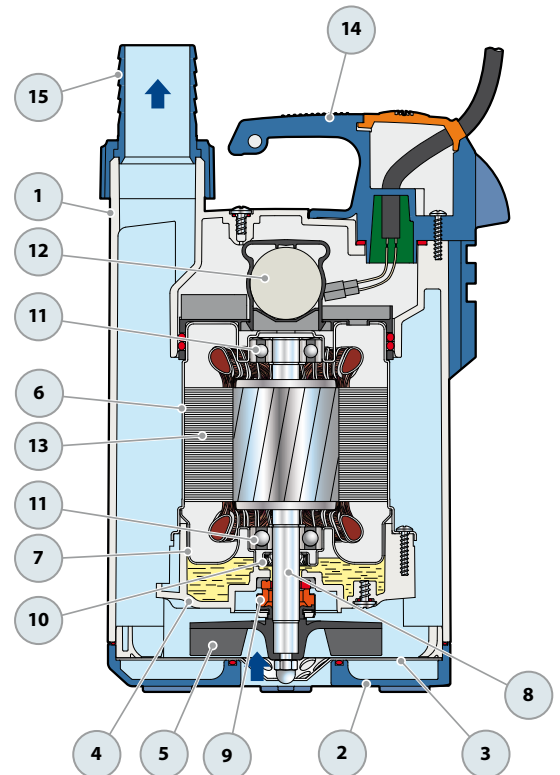

## DIMENSIONS AND WEIGHT

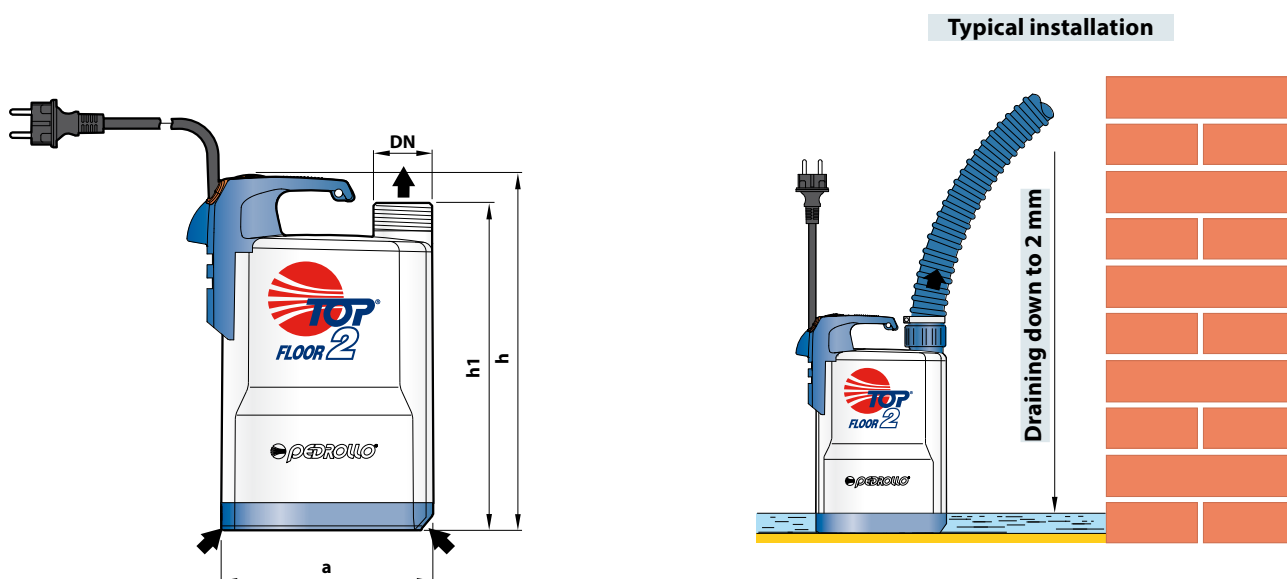

MODEL	PORT DN	a	DIMENSIONS mm			Minimum drying level	kg
			h	h1			
TOP 1-FLOOR	1¼"	152	257	237	2 mm	5.1	
TOP 2-FLOOR						5.2	
TOP 3-FLOOR						6.6	

## ABSORPTION

MODEL	VOLTAGE		
	220 V	110 V	127 V
TOP 1-FLOOR	1.5 A	3.0 A	2.6 A
TOP 2-FLOOR	2.5 A	5.0 A	4.3 A
TOP 3-FLOOR	3.7 A	8.6 A	6.8 A

## PALLETIZATION

MODEL	GROUPAGE	CONTAINER
Single-phase	n. pumps	n. pumps
TOP 1-FLOOR	96	144
TOP 2-FLOOR	96	144
TOP 3-FLOOR	96	144